

## 1. Introduction

Module **A-155** (Analog / Trigger Sequencer) is a combined **8-step analog and trigger sequencer**: it can simultaneously produce sequences of analog voltages and trigger and/or gate signals.

Module A-155 works very much like the Clock Sequencer module, A-161, but includes many extra (and expensive to implement!) functions.

The **control section** includes switches for **Start, Stop, Step** and **Reset** - which can be operated by **push-button** as well as **digital signals**. Above the top row, **eight LEDs** show the progress of the sequence, with each step's LED lighting in turn.

The A-155 has two **analog rows**, each with **eight knobs**, with which to set the control voltage for each step. The upper row is particularly designed for pitch control of a VCO, with a **range switch** giving the ability to set pitches precisely.

The lower row of eight knobs has the ability to accept an **external signal for each step**, in which case the knobs act as attenuators for this voltage.

The variable voltages from the analog rows can either be output direct, or can go through a **sample-and-hold** section and a **slew limiter ('glide')**. Using the **S&H** and **glide control inputs**, it's possible to select 'hold' (S&H) or portamento (glide) for whichever step or steps you want.

**Three rows of triggers** and **one row of gates** are available. For each step, a three-way mini-switch lets you decide whether one or the other (or neither) of the two triggers works. Each row has an **LED** which lights whenever a trigger or gate is active at any particular step.

2. Overview

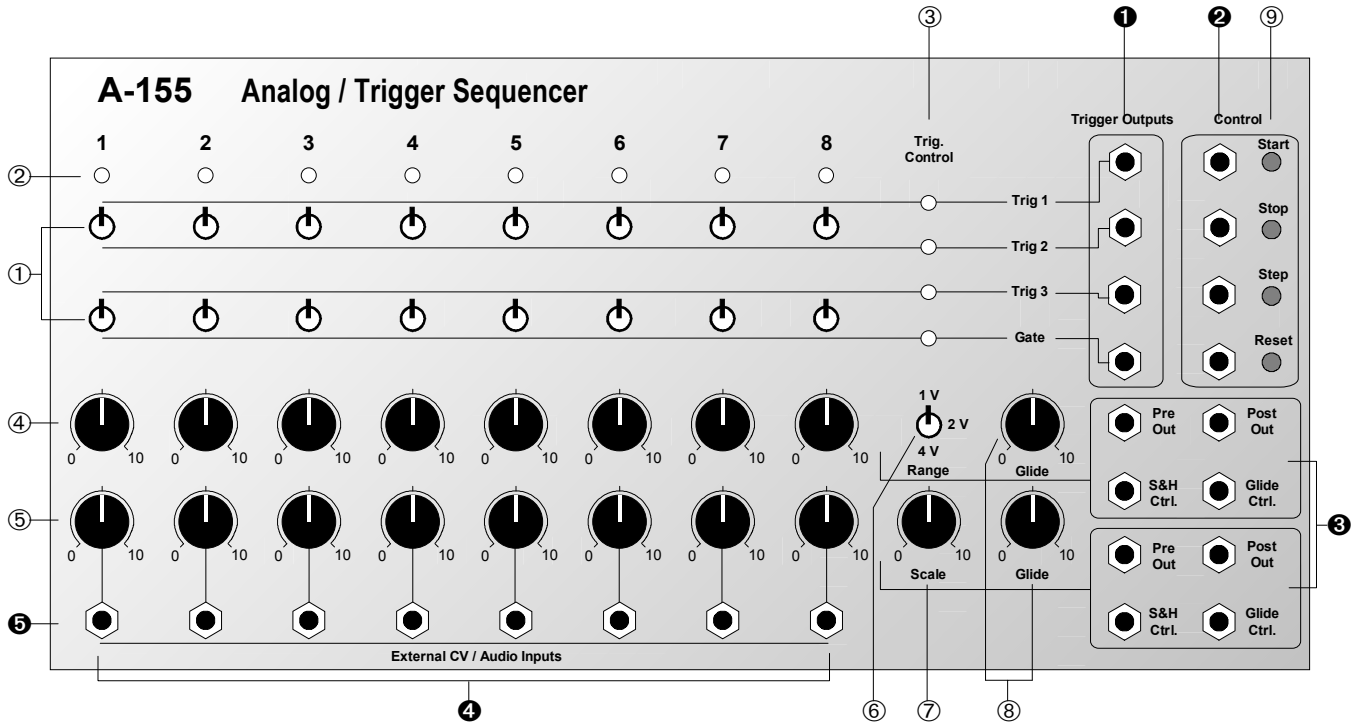

## Controls

- ① **Switches** : these select triggers and/or gates for each step
- ② **LEDs** : indicators to show the step reached
- ③ **Trig. Control**: indicators for trigger and gate rows
- ④ **CV knob**: these set the control voltage output for each step of the upper CV row
- ⑤ **CV knob**: these set the control voltage output for each step of the lower CV row, and/or act as attenuators for the external CV / audio inputs
- ⑥ **Range** : switch to select the voltage range of the CVs put out by the upper CV row
- ⑦ **Scale** : range control for the lower CV row
- ⑧ **Glide** : control for the glide time (amount of slew) on either upper or lower CV row
- ⑨ **Control** : manual controls
  - Start** : start button
  - Stop** : stop button
  - Step** : button for manually stepping through a sequence
  - Reset** : reset button

## In / Outputs

- ① **Trigger Out** : outputs for the three triggers and one gate
- ② **Control** : digital control input sockets
  - Start** : input for start signal
  - Stop** : input for stop signal
  - Step** : input for clock signal
  - Reset** : input for reset signal
- ③ **CV outputs, control inputs** :
  - Pre Out** : output for the upper or lower analogue CV row
  - Post Out** : as above, but after the sample-and-hold and/or glide circuitry
  - S&H Ctrl.** : control input for sample-and-hold section
  - Glide Ctrl.** : control input for the glide section
- ④ **External CV/ Audio Inputs** : inputs for controlling the voltage of each step of the lower analog CV row by a CV or audio signal

### 3. Controls

#### ① Switches

The three-position toggle switches ① are used to select whether a particular step outputs a trigger signal on its respective row.

Position of the **upper switches**:

- **up:** trigger output on row 1 (Trig 1 output)
- **centre:** no trigger output
- **down:** trigger output on row 2 (Trig 2 output)

Position of the **lower switches**:

- **up:** trigger output on row 3 (Trig 3 output)
- **centre:** no trigger output
- **down:** gate output on row 4 (Gate output)

The three upper rows produce triggers - each step that is switched to a row will produce a short pulse like a clock signal. The lowest row produces gates - the signal remains "high" for the duration of the step (see fig. 1 on the next page).

#### ② LEDs

The eight LEDs ② show the sequence's progress; each LED lights when its respective step is active.

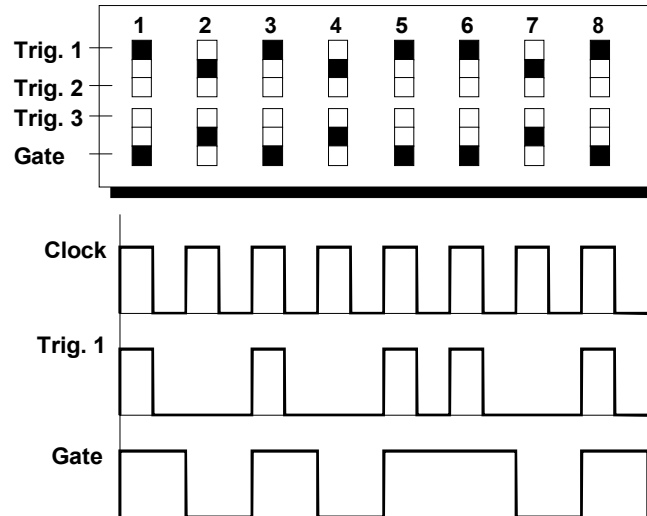

fig. 1: timing diagram for trigger and gate rows

#### ③ Trig. Control

The four LEDs ③ are status indicators for the trigger and gate rows. Each lights when a step is reached which is switched to its own row.

#### ④ CV knobs (upper row)

You use the CV knobs ④ (upper row) to set the **voltage output for each step** in the upper analog CV row. The control voltage set for each step is output at the upper **Pre Out** ③ socket.

The **range of voltage output** can be controlled with the range switch ⑥. Three very accurate voltage ranges are provided (see below) so that the upper analog CV row is ideally suited for precise **VCO pitch control**.

#### ⑤ CV knobs (lower row)

You use the CV knobs ⑤ (lower row) to set the **voltage output for each step** in the lower analog CV row. The control voltage set for each step is output at the lower **Pre Out** ③ socket.

You use the **Scale control** ⑦ to adjust the **range** of the voltages controlled by the CV knobs.



If for any step you patch in an **external CV / audio input** (socket ④), the corresponding-knob in the lower row doesn't put out its own voltage.

Instead, it acts as an **attenuator** for the external CV / audio signal, before sending it to the lower **Pre Out** output ③.

#### ⑥ Range

The position of the **Range switch** (a three-way toggle switch) ⑥ selects the precise **voltage control range**, within which the upper row of CV knobs ④ will operate. There are three ranges to choose from:

- **up** : 1 V (i.e. one octave)
- **centre** : 2 V (i.e. two octaves)
- **down** : 4 V (i.e. four octaves).

The maximum voltage is obtained by turning the knobs fully clockwise.

#### ⑦ Scale

Control ⑦ sets the **range of control voltages**, within which the lower row of CV knobs ⑤ will operate. If an external CV / audio signal is patched into any of the sockets ④, the scale control affects the amount of **attenuation** the CV knob will produce on that voltage.

#### ⑧ Glide

The internal **slew limiter's** rate is set with control ⑧. If for the current step in a sequence (e.g. step three) the slew limiter is switched in (by a **"low"** control signal at the **Glide Ctrl.** ③ socket), the control voltage sent to output **Post Out** ③ doesn't jump instantly from the voltage at the previous step (in this example, step two). Instead, it glides gradually to the new voltage, at

a speed determined by the Glide control knob (fig. 2).

If you patch the output from the Gate row into the **Glide Ctrl.** input ⑨, you can **switch the glide function on or off for each step**, like on the Roland TB-303 (see fig. 2). If you patch the gate output through an A-165 trigger modifier, every gate activates 'glide'.

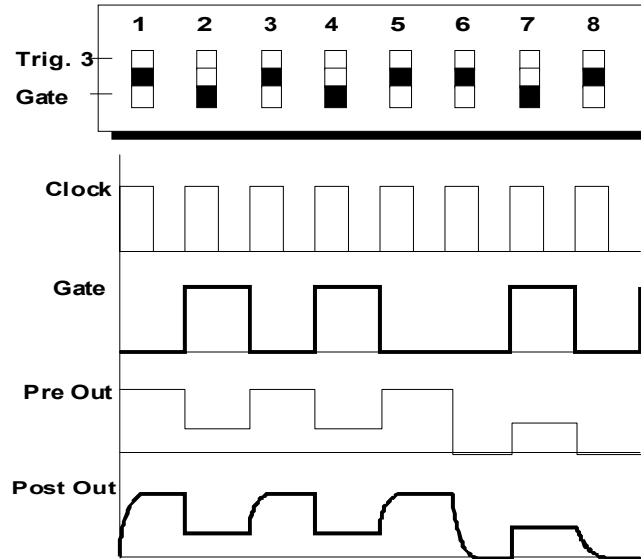

fig. 2: glide function

## ⑨ Control

The **control section** ⑨ includes four push-buttons for manual sequencer control. Alternatively, digital control signals can be sent to four corresponding sockets.

- **Start** : Used to start the sequence - i.e. to set it running.
- **Stop** : Used to stop the sequence.
- **Step** : Used to step through the sequence one step at a time. Each button-press corresponds to a clock pulse.
- **Reset** : Used to 'reset' the sequence - i.e. to send it back to begin again at step one.

## 4. In / Outputs

### ① Trigger Outputs

Sockets ① are the outputs from the **three trigger rows** and the **gate row**.

### ② Control

Alongside the four buttons for sequencer control, there are four corresponding digital control input sockets ②.

- **Start** : A signal here starts the sequence.
- **Stop** : A signal here stops the sequence.
- **Clock** : A **clock signal** here steps through the sequence. Also called 'step' input.
- **Reset** : A signal here sends the sequence back to step one.



**Start and Stop inputs** work in **trigger mode**. As soon as they sense the rising edge of a pulse, they produce a momentary signal. The length of the pulse makes no difference - a pulse of long duration still just produces a momentary trigger.

**Clock (step)** and **Reset inputs**, on the other hand, work by sensing level: so, for instance, Reset will always be active (keeping the sequence at step one) as long as the reset signal is "high".

### ③ CV outputs, control inputs

The two groups of sockets ③ contain the **analog CV outputs** for each row, and the **digital control inputs** for the sample-and-hold and slew limiter sections.

The upper group of sockets relates to **analog CV row 1**, and the lower to **analog CV row 2**.

- **Pre Out** : The **control voltages** set on the respective analog CV row are output here, **before** (*pre*) passing through the slew limiter and sample-and-hold sections.
- **Post Out** : The **control voltages** set on the respective analog CV row are output here, **after** (*post*) passing through the slew limiter and sample-and-hold sections.

- **Glide Ctrl.** : The glide function is active whenever the control signal input here is "low".  
: If nothing's connected to the socket, glide function is active!
- **S&H Ctrl.** : This is the socket for the digital **Sample & Hold control input**. Whenever a "high" control signal is sensed, the analog CV output is held at the same level until the control signal goes low. Usually one of the trigger rows would be patched in to this socket.



The purpose of this 'hold' function becomes clear if you e.g. want to hold the pitch of a VCO over 2 or more steps. In this case the S&H function takes care that the CV is held over the regarding steps provided that the S&H control input is connected to one of the trigger outputs and the trigger switches are set suitable. Without the use of the S&H you would have to adjust the potentiometers of the regarding steps very careful to obtain exactly the same voltage for the successive steps.

## ④ External CV / Audio Inputs

The inputs ④ for the **lower analog CV row** can be used to patch in any **control voltage or audio signal**.

For any step used in this way, the CV knob ⑤ then acts as an attenuator for the signal input.

## 5. User examples

Module A-155 has limitless potential. All sorts of very complex sequences, modulation and audio manipulation are possible. In the following examples of typical patches, there's only room to mention a few of the most common uses.

Fig. 3 shows a **standard patch** - a six-step sequence with pitch, filter and glide control, to give an example of some of the typical control possibilities the A-155 provides.

The **upper analog CV row** is controlling the **pitch** of the VCO. In this example, output "Post Out 1" has been chosen, because the glide function is being used.



**Trigger row 1** (steps 1, 2, 3 and 5 selected) picks out the **accented notes**, by triggering an ADSR, which controls the VCA.

**Trigger row 2** determines the **length of the sequence**, by triggering the **reset** function. In this example, step seven is switched to this row, which is patched to the reset input, making the sequence six notes long.

The **gate row** is used for controlling the **glide function**. In this example, step two is switched to this row, so that portamento (at a rate set by the Glide control) occurs between the voltages at step one and step two.

The **lower analog CV row** is controlling the **VCF cut-off frequency**.

Trigger row 3 is available for any other control job you choose. Variations on the patch in fig. 3 might include controlling the VCF with either the same or a different ADSR, or using the lower analog CV row to control the decay time of a VC-ADSR (see also fig. 4).

Interesting effects can be obtained by patching **external control voltages** (e.g. from an LFO or Random CV) or **audio signals** (e.g. VCO or Noise) into the lower analog CV row. The latter can sound particularly interesting, because of the effects of short bursts of audio-range frequency modulation.

Interesting effects can be obtained by patching **external control voltages** (e.g. from an LFO or Random CV) or **audio signals** (e.g. VCO or Noise) into the lower analog CV row. The latter can sound particularly interesting, because of the effects of short bursts of audio-range frequency modulation.



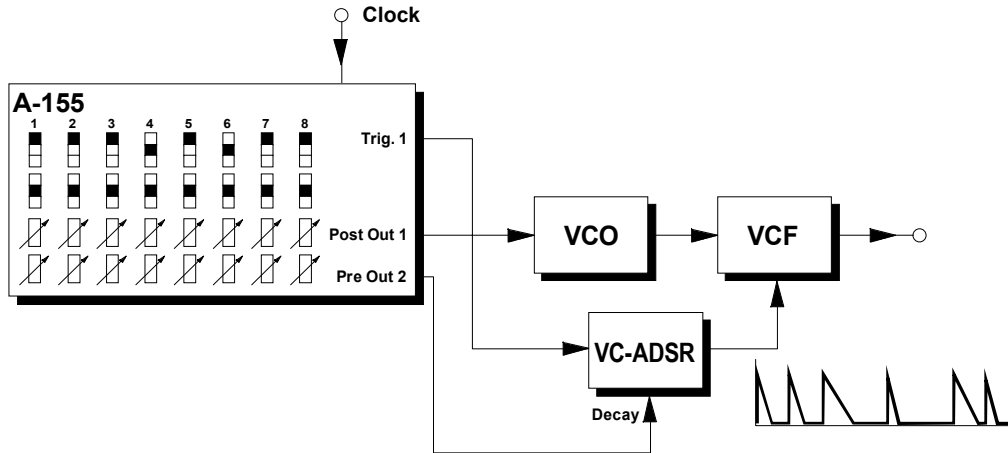

fig. 4: controlling decay time in a VC-ADSR

In fig. 4 the lower analog CV row controls the **decay time of a VC-ADSR**. This in turn controls the cut-off frequency of a VCF, and so produces filter accents of different lengths.

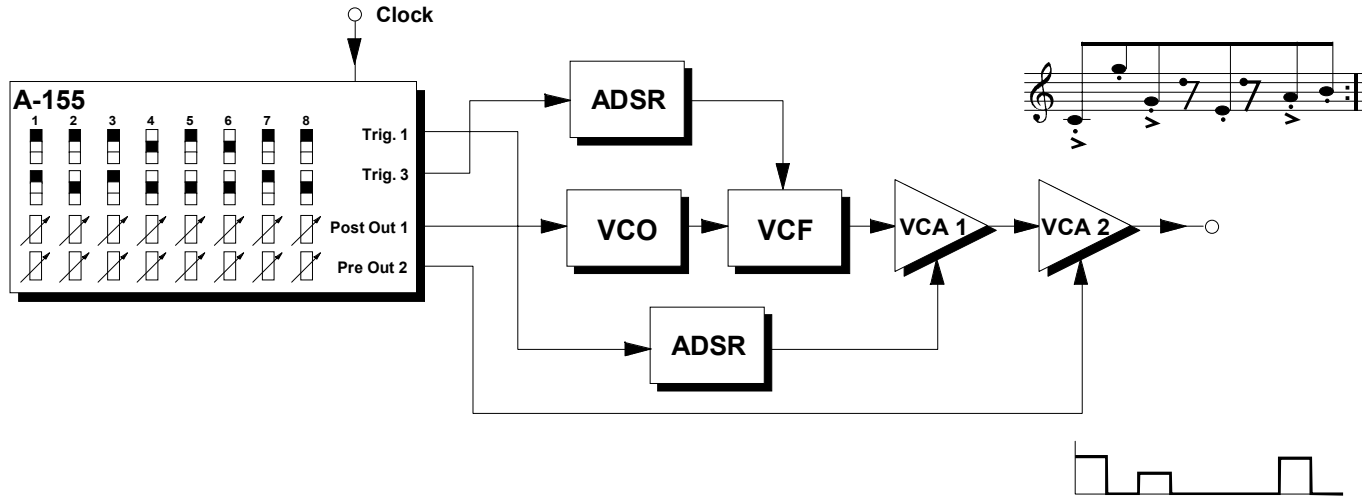

fig. 5: controlling accents / dynamics

With the patch in fig. 5 you can create **variable dynamics or accents** within the sequence. The gain control of **VCA 2** needs to be set to **greater than zero** (a setting of 5 is a good starting point).

The patch in fig. 6 shows how to use the A-155 as a **16-step sequencer** with one single analog CV row. What's needed are the Clock Divider A-160 (output /8) and the two voltage-controlled switches in the A-150 VCS module.

With every eight clock pulses, the A-150 switches between the two trigger and analog CV rows, so that there's now a 16-step trigger and CV sequence available at the outputs of the A-150.

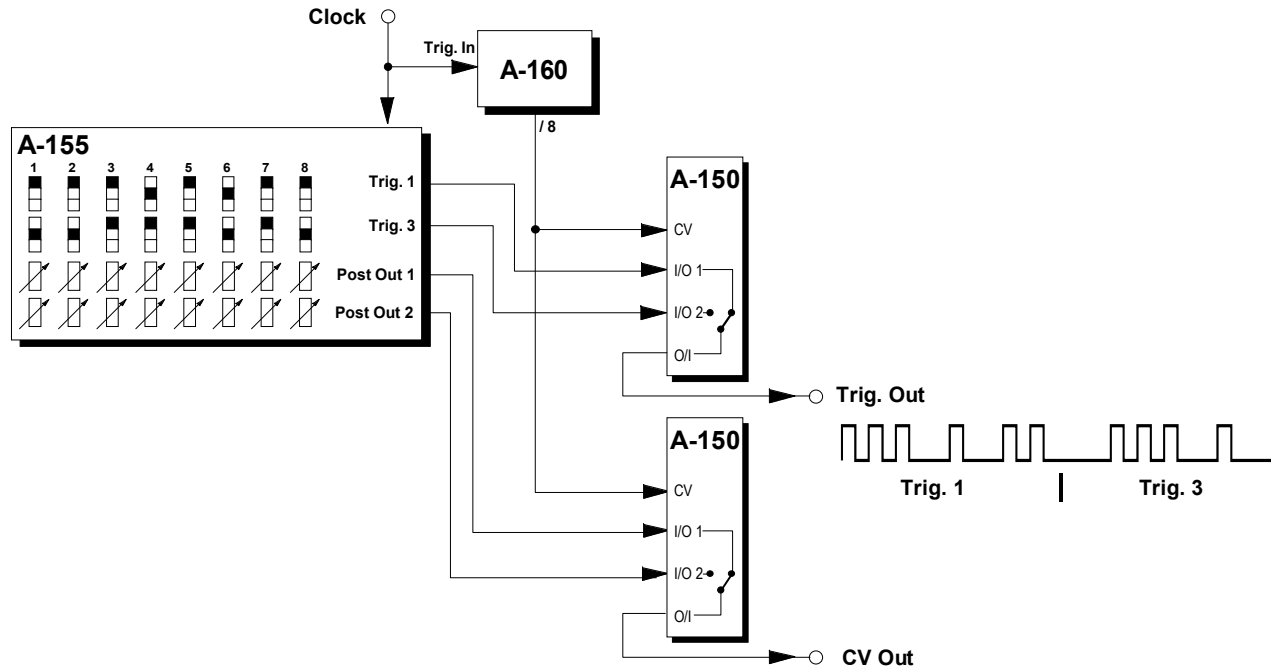

fig. 6: 16-step sequence with single analog CVs

The following are some short notes with suggestions for further exploration, to act as inspiration for your own patching ideas.

- **Gate patched to glide control**  
Glide / portamento can be switched on or off for each step (a la TB-303, see. p. 6).
- **Trigger (Gate) patched to Reset**  
Shortening a sequence to, e.g., six notes.
- **Trigger (Gate) patched to Stop**  
"One shot": the sequence runs just once, and only repeats when a Start signal is received.
- **Chopping up audio signals**  
Using the lower analog CV row, audio signals patched into the inputs will be output 'chopped up' from the Pre Out socket.
- **MIDI control**  
The A-155 can be controlled by MIDI-Clock with the help of an A-190 module; the Clock and Reset outputs of the A-190 are simply connected to the Clock and Reset inputs on the A-155.

- **Random Clock**  
The Random Clock output from the A-117 can give a sequence random timing.
- **VC-LFO as Clock**  
Using one of the analog CV rows to control a VC-LFO (A-147), the timing of each step of the sequence can be completely variable.
- **Variable decay time for each step**  
Using one analog CV row to control the decay time on a VC-ADSR (A-141 or A-142 - and on the A-141 attack and release times could also be controlled) the envelope output can then control, e.g., a VCF or VCA.
- **Variable audio pulse width for each step**  
Using one analog CV row to control the pulse width of a VCO square wave.

### **Variable control pulse width for each step**

Using one analog CV row to control decay on an A-142 (and taking the gate output from the A-142).

## 6. Patch-Sheet

The following diagram of the module can help you recall your own **Patches**. It's designed so that a complete 19" rack of modules will fit onto an A4 sheet of paper.

Photocopy this page, and cut out the pictures of this and your other modules. You can then stick them onto another piece of paper, and create a diagram of your own system.

Make multiple copies of your composite diagram, and use them for remembering good patches and set-ups.



- Draw in patchleads with colored pens.
- Draw or write control settings in the little white circles.

